

LCL Series



- Single Output Industrial Supplies
- High Efficiency
- Low Cost
- 150 W Convection Cooled
- 300 W & 500 W with Internal Fans
- Outputs from 12 V to 48 V
- 3 Year Warranty

Specification

Input

Input Voltage	• 85-264 VAC (127-370 VDC) (see note 1)
Input Frequency	• 47-63 Hz
Input Current	• 2.1 A max for LCL150, 4.5 A max for LCL300, 6.6 A max for LCL500
Inrush Current	• 40 A max for LCL150, 60 A max for LCL300 & 500 cold start at 25 °C, 230 VAC
Power Factor	• >0.9
Earth Leakage Current	• <2 mA at 264 VAC, 60 Hz
Input Protection	• LCL150: T3.15 A/250 V, LCL300: T6.3A/250 V, LCL500: T10A/250 V, internal fuse fitted in line

Output

Output Voltage	• See tables
Output Voltage Trim	• See tables
Initial Set Accuracy	• ±100 mV at 50% load
Minimum Load	• None required
Start Up Delay	• 2 s max for LCL150, 1.5 s max for LCL300, 0.8 s max for LCL500
Start Up Rise Time	• 50 ms max for LCL150, 35 ms max for LCL300 & LCL500
Hold Up Time	• 10 ms min at 115 VAC and full load
Line Regulation	• ±0.5% max for LCL150, ±0.3% for LCL300 & LCL500
Load Regulation	• ±1% max
Transient Response	• 4% max deviation recovery to within 1% in 500 µs for a 50% load change
Ripple & Noise	• See tables
Overvoltage Protection	• 115-135%, recycle input to reset
Overtemperature Protection	• Output turns off when OTP triggered, measured internally, auto recovery
Overload Protection	• 110-140% of rated output power. Delayed by 1 s min to allow for peak loads.
Short Circuit Protection	• Trip and restart (hiccup mode), auto recovery
Remote Sense	• Fitted to LCL500 only, compensates for 0.25 V max each line
Remote On/Off	• Fitted on LCL300 & 500 only, On = logic low or open circuit, Off = logic high

General

Efficiency	• 88% typical at full load & 230 VAC
Isolation	• 3000 VAC Input to Output 1500 VAC Input to Ground 500 VAC Output to Ground
Switching Frequency	• 90-110 kHz main converter & 45-190 kHz PFC for LCL150, 80-190 kHz main converter & 62-65 kHz PFC for LCL300 & 500
Power Density	• 2.7 W/in ³ LCL150, 4.4 W/in ³ LCL300, 4.9 W/in ³ LCL500
MTBF	• LCL150: >489 kHrs, LCL300: >235 kHrs, LCL500: >211 kHrs to MIL-HBK-217F at 25 °C, GB

Environmental

Operating Temperature	• -10 °C to +70 °C, derate from 100% load at 50 °C to 50% load at 70 °C
Cooling	• LCL150 convection cooled, LCL300 & LCL500 have internal fans
Operating Humidity	• 5% to 90% non condensing
Storage Temperature	• -40 °C to +85 °C
Operating Altitude	• 3000 m
Vibration	• 10-500 Hz, 2 g, 10 mins per cycle on 3 axes

EMC & Safety

Emissions	• EN55022 level B conducted, level A radiated
Harmonic Currents	• EN61000-3-2 class A LCL150: EN61000-3-2 class C for loads ≥40% LCL300 & LCL500: EN61000-3-2 class C for loads ≥20%
Voltage Flicker	• EN61000-3-3
ESD Immunity	• EN61000-4-2, ±4 kV contact, ±8 kV air discharge, Performance Criteria A
Radiated Immunity	• EN61000-4-3, level 2 Perf Criteria A
EFT/Burst	• EN61000-4-4, level 2 Perf Criteria A
Surge	• EN61000-4-5, installation class 3, Perf Criteria A
Conducted Immunity	• EN61000-4-6, level 2 Perf Criteria A
Magnetic Field	• EN61000-4-8, 1 A/m Perf Criteria A
Dips & Interruptions	• EN61000-4-11, 30% 10 ms, 60% 100 ms, 100% 5000 ms, Perf Criteria A, B, B
Safety Approvals	• EN60950-1, UL60950-1, CSA60950 No 22.2

Model and Ratings

Output Power ⁽¹⁾	Output Voltage	Trim Range	Output Current	Ripple & Noise ⁽²⁾	Model Number
150 W	12.0 V	11.0-13.0 V	12.5 A	100 mV pk-pk	LCL150PS12†^
	13.5 V	12.5-14.5 V	11.1 A	100 mV pk-pk	LCL150PS13
	15.0 V	14.0-16.0 V	10.0 A	100 mV pk-pk	LCL150PS15†^
	24.0 V	23.0-25.0 V	6.3 A	150 mV pk-pk	LCL150PS24†^
	27.0 V	26.0-28.0 V	5.6 A	150 mV pk-pk	LCL150PS27
	48.0 V	47.0-49.0 V	3.1 A	250 mV pk-pk	LCL150PS48†^

Notes

1. Output power derates linearly from 100% at 90 VAC to 90% at 85 VAC.
2. Measured with 20 MHz bandwidth.

† Available from Farnell & element14. See pages 284-290.

^ Available from Newark. See pages 291-296

Mechanical Details

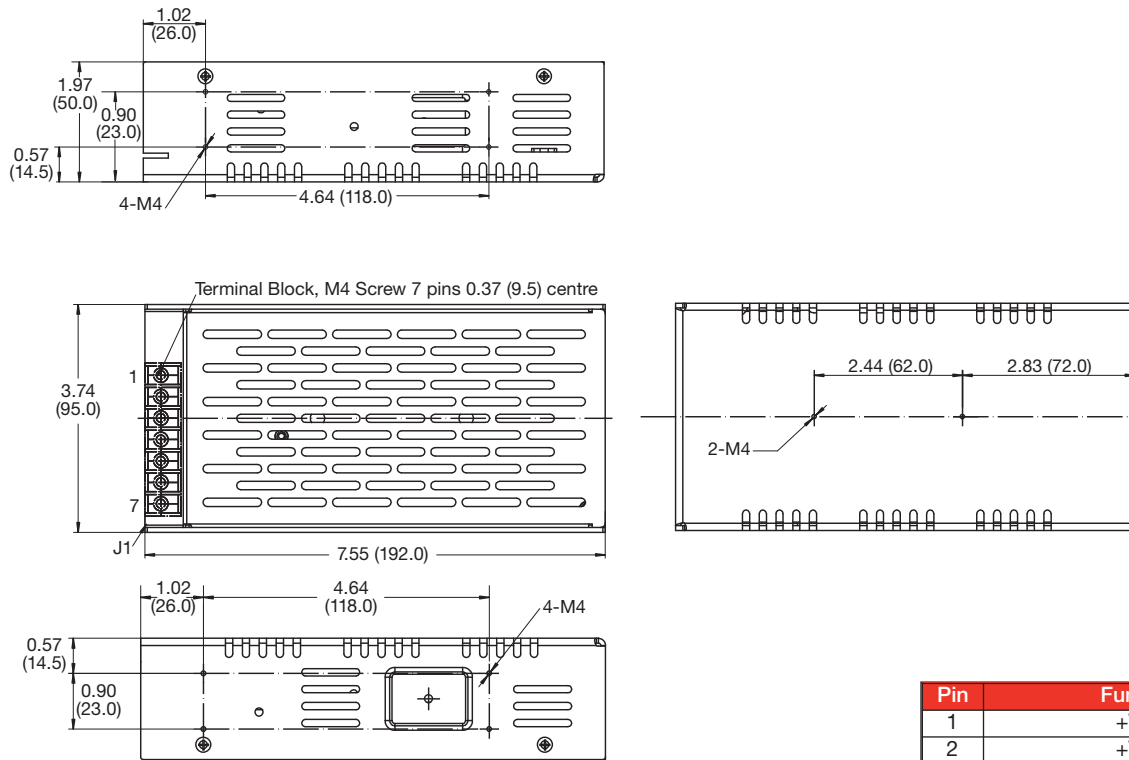

Pin	Function
1	+Vout
2	+Vout
3	-Vout
4	-Vout
5	Ground
6	Neutral
7	Line

Notes

1. All dimensions shown in inches (mm).
2. Weight: 1.39 lbs (630 g) approx.
3. Tolerance is ± 0.05 (± 0.2) maximum.

Derating Curves

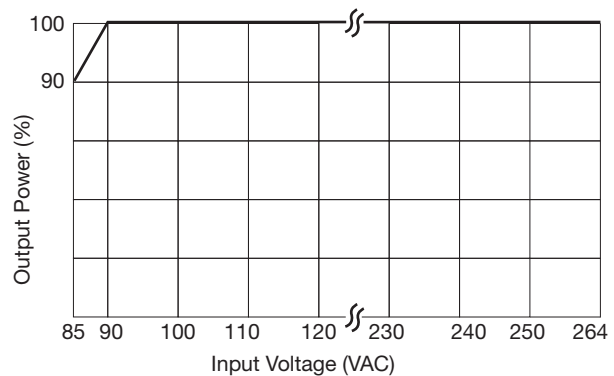
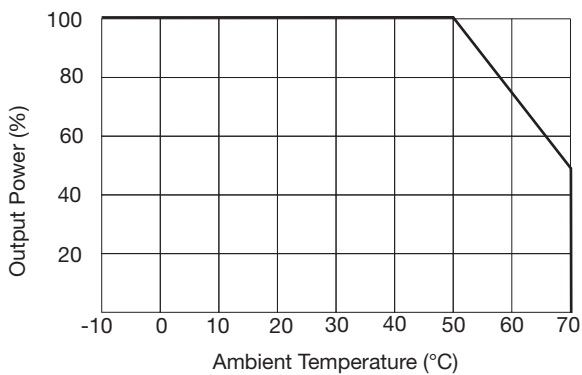

Output Power ⁽¹⁾	Output Voltage	Trim Range	Output Current	Ripple & Noise ⁽²⁾	Model Number
300 W	12.0 V	11.0-13.0 V	25.0 A	150 mV pk-pk	LCL300PS12†^
	13.5 V	12.5-14.5 V	22.0 A	150 mV pk-pk	LCL300PS13
	15.0 V	14.0-16.0 V	20.0 A	150 mV pk-pk	LCL300PS15†^
310 W	24.0 V	23.0-25.0 V	13.0 A	150 mV pk-pk	LCL300PS24†^
315 W	27.0 V	26.0-28.0 V	11.7 A	200 mV pk-pk	LCL300PS27
320 W	48.0 V	47.0-49.0 V	6.70 A	240 mV pk-pk	LCL300PS48†^

Notes

1. Output power derates linearly from 100% at 90 VAC to 90% at 85 VAC.
2. Measured with 20 MHz bandwidth.

† Available from Farnell & element14. See pages 284-290.

^ Available from Newark. See pages 291-296

Mechanical Details

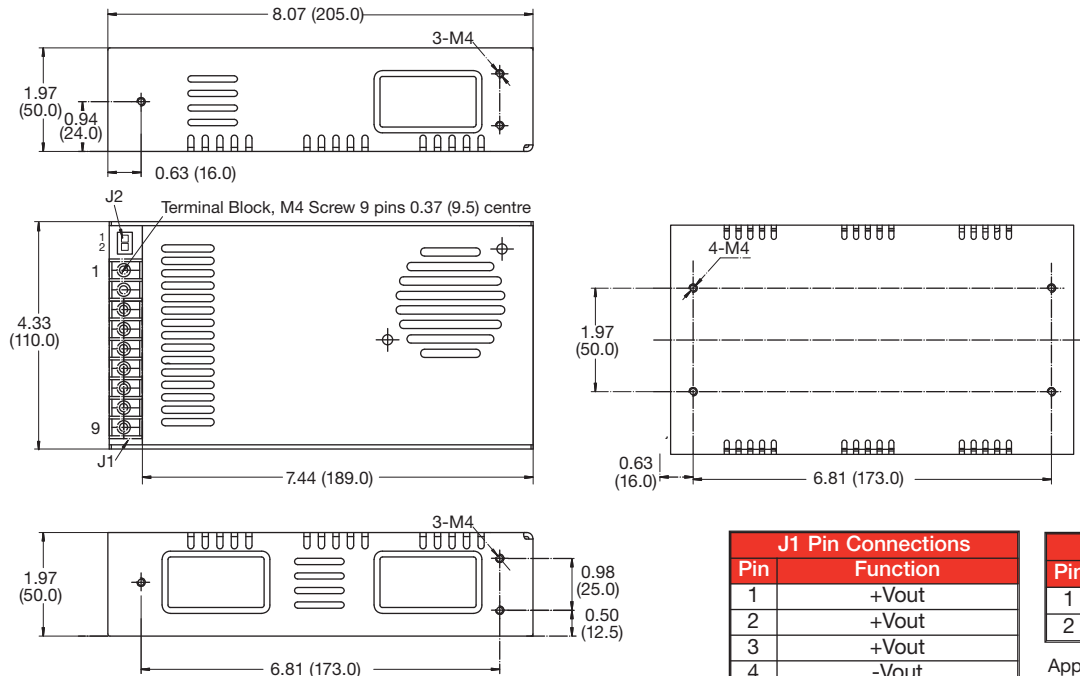

Notes

1. All dimensions shown in inches (mm)
2. Weight: 1.94 lbs (880 g) approx.
3. Tolerance is ±0.05 (±0.2) maximum.

Derating Curves

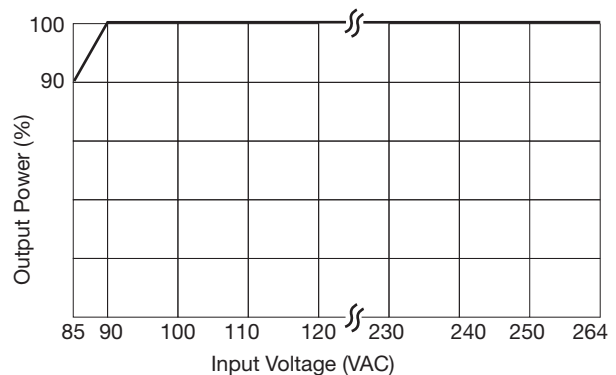
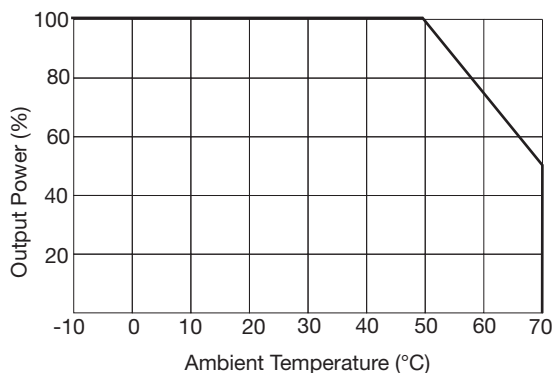

Model and Ratings

Output Power ⁽¹⁾	Output Voltage	Trim Range	Output Current	Ripple & Noise ⁽²⁾	Model Number
500 W	12.0 V	11.0-13.0 V	42.0 A	120 mV pk-pk	LCL500PS12†^
	13.5 V	12.5-14.5 V	37.0 A	150 mV pk-pk	LCL500PS13
	15.0 V	14.0-16.0 V	34.0 A	150 mV pk-pk	LCL500PS15†^
	24.0 V	23.0-25.0 V	21.0 A	150 mV pk-pk	LCL500PS24†^
	27.0 V	26.0-28.0 V	18.5 A	150 mV pk-pk	LCL500PS27
	48.0 V	47.0-49.0 V	10.5 A	240 mV pk-pk	LCL500PS48†^

Notes

1. Output power derates linearly from 100% at 90 VAC to 90% at 85 VAC.
2. Measured with 20 MHz bandwidth.

† Available from Farnell & element14. See pages 284-290.

^ Available from Newark. See pages 291-296

Mechanical Details

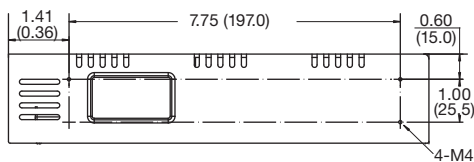
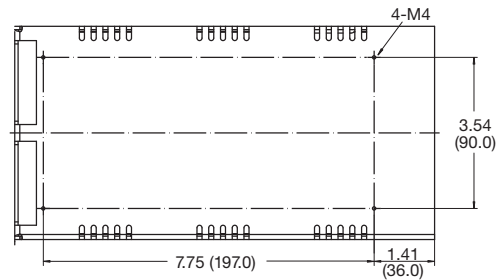
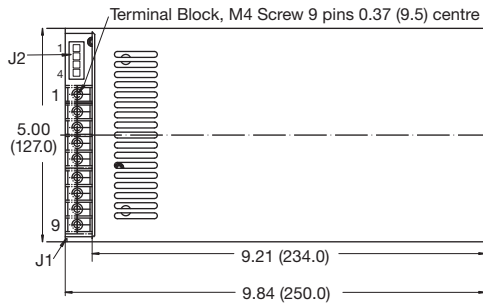
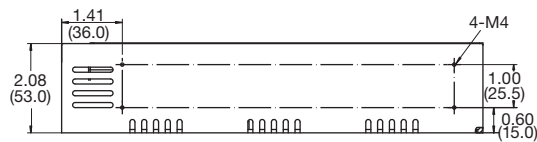

J1 Pin Connections	
Pin	Function
1	+Vout
2	+Vout
3	+Vout
4	-Vout
5	-Vout
6	-Vout
7	Ground
8	Neutral
9	Line

J2 Pin Connections	
Pin	Function
1	Remote On/Off -
2	Remote On/Off +
3	Sense -
4	Sense +

Applying >4.5 V to Pin 2 with respect to Pin 1 turns output off.
Applying <0.8 V to Pin 2 with respect to Pin 1 or open circuit turns output on.

Mating Connectors (J2):
WST P4-I25002 housing
WST I25002BS contacts

Notes

1. Dimensions shown in inches (mm).
2. Weight: 3.2 lbs (1.45 kg) approx.
3. Tolerance is ± 0.05 (± 0.2) maximum.

Derating Curves

