



DSX Access Systems, Inc.

DSX-IP-HUB Configuration

Programming and Commissioning the DSX-IP-HUB

The **DSX-IP-HUB** is a DSX Controller communications router. It allows communication from the Master Controller to be distributed via IP to Sub Controllers using regular LAN Modules. In some applications this Module can take the place of PC Master software with the difference being it requires a Master Controller.

1. The DSX-IP-Hub Module comes with a preset IP Address of **192.168.1.25** and can be programmed with a web browser. Connect the module to your laptop or network switch and connect using a browser. The module requires **5-12VDC @ 300ma**. Power the module from the **5VDC** output of the 1040-CDM or 1022 Controller. Wiring info on last two pages.

2. Using the browser enter the default IP Address of **192.168.1.25** with a Laptop or PC that has the same IP Schema and subnet. Using a browser enter the IP address and press enter. The DSX-IP-Hub will respond with a Login page where you will enter:
User - master, Password - master. The screen shots below show the default Settings for the module.

3. Once you have logged in, you will be able to program the module. On the Communications Settings Tab - Do Not Change the top 5 items unless instructed to do so. The Serial Port Speed should be 9600, Internet Protocol should be **IPv4**, the Addressing Mode should be **Static (v4 or v6)** and the Link Speed should be **Auto Negotiate**.

Communication Settings	Device Address Table	Security Settings
Device name for DHCP:	<input type="text" value="DSX-00-08-66-10-00-97"/>	
Serial Port Speed:	<input type="text" value="9600"/> <small>Serial Port Speed must match DSX Panel Serial Speed</small>	
Internet Protocol:	<input type="text" value="IPv4"/>	
Addressing mode:	<input type="text" value="Static(v4 or v6)"/>	
Link Speed/Duplex:	<input type="text" value="Auto Negotiate"/>	

4. Under IP Settings assign a Static IP Address, Subnet mask, Gateway, and DNS server. Leave VLAN at 0 unless you are placing the module on a VLAN. Perform "IPConfig" from a command prompt to find the data below.

IP Settings	IP Values
Device IP address:	<input type="text" value="192.168.1.25"/> <small>MAC Address:00-08-66-10-00-97</small>
Device subnet mask:	<input type="text" value="255.255.255.0"/>
Device gateway:	<input type="text" value="255.255.255.255"/>
DNS server:	<input type="text" value="255.255.255.255"/>
VLAN ID:	<input type="text" value="0"/> <small>Enter 0 to disable VLAN</small>

5. Under the UDP Settings enter the same user defined port number in the **Receive and Transmit Port** fields. This will be the same port number as the **Receive and Transmit Ports** of the DSX-LAN modules connected to Sub Controllers or clusters of Sub Controllers regardless of version.

UDP Settings	
Receive Port	Transmit Port
5000	5000
Submit New Settings	

[Click on Print for a copy of these settings](#)

6. Click on **Submit New Settings** to save. You must save before changing screens.

Example of IP-HUB at Master Controller

Communication Settings	Device Address Table	Security Settings
Device name for DHCP:	DSX-00-08-66-10-00-97	
Serial Port Speed:	9600 <small>Serial Port Speed must match DSX Panel Serial Speed</small>	
Internet Protocol:	IPv4	
Addressing mode:	Static(v4 or v6)	
Link Speed/Duplex:	Auto Negotiate	
IP Settings	IP Values	
Device IP address:	182.25.16.139	MAC Address:00-08-
Device subnet mask:	255.255.0.0	
Device gateway:	182.25.16.26	
DNS server:	182.25.16.3	
VLAN ID:	0	<small>Enter 0 to disable VLAN</small>
UDP Settings	Receive Port	Transmit Port
	5000	5000
Submit New Settings		

Example of LAN-D and LAN at Sub Controllers

Communication Settings	Security Settings
Device name for DHCP:	DSX-00-08-66-10-00-F0
Serial Port Speed:	9600 <small>Serial Port Speed must match DSX Panel Serial Speed</small>
Internet Protocol:	IPv4
Addressing mode:	Static(v4 or v6)
Link Speed/Duplex:	Auto Negotiate
IP Settings	IP Values
Device IP address:	182.25.16.136
Device subnet mask:	255.255.0.0
Device gateway:	182.25.16.26
DNS server:	182.25.16.3
VLAN ID:	0 <small>Enter 0 to disable VLAN</small>
UDP Settings	Receive Port
	5000
Send to this IP address:	IPv4,IPv6 or DNS lookup
Dynamic IP:	<input checked="" type="checkbox"/>
Submit New Settings	

7. Select the **Device Address Table** Tab. Here you will enter the **IP Address** of the DSX-LAN modules that are connected to Sub Controllers or clusters of Sub Controllers and the **Device** numbers connected to each one. In the example below there is an IP Address and then a Device List. Enter the IP Address and then click on Devices and enter the Device numbers separated with a comma. The example below shows one of three DSX-LAN modules with an IP Address of 182.25.16.136 that is connected to Devices 8,10,12, and 14. A LAN module can connect to each Sub or a cluster of Sub controllers. **Click Submit** when finished.

Communication Settings	Device Address Table	Security Settings												
	<table border="1"> <thead> <tr> <th>Select</th> <th>IP Address</th> <th>Devices</th> </tr> </thead> <tbody> <tr> <td><input type="checkbox"/></td> <td>182.25.16.136</td> <td>8,10,12,14</td> </tr> <tr> <td><input type="checkbox"/></td> <td>182.25.16.137</td> <td>16,18,20,22,24,26,28,30</td> </tr> <tr> <td><input type="checkbox"/></td> <td>182.25.16.138</td> <td>32</td> </tr> </tbody> </table>	Select	IP Address	Devices	<input type="checkbox"/>	182.25.16.136	8,10,12,14	<input type="checkbox"/>	182.25.16.137	16,18,20,22,24,26,28,30	<input type="checkbox"/>	182.25.16.138	32	
Select	IP Address	Devices												
<input type="checkbox"/>	182.25.16.136	8,10,12,14												
<input type="checkbox"/>	182.25.16.137	16,18,20,22,24,26,28,30												
<input type="checkbox"/>	182.25.16.138	32												
Delete Row(s) Add Row Submit New Settings														
Print														

- Enter the IP Address and then the Devices separated by a comma. Then Click on **Add Row** to enter another IP Address and Device List. Enter Even Number Addresses Only.
- ***** *Connect no more than 8 controllers per LAN Device. More than 8 controllers will diminish performance.* *****

8. Under Security Settings - set the **User** Name and Password and the **Admin** User Name and Password. The User can change Communication Settings and the Admin can change Security and Communications Settings. Use the **Password Format** section at the bottom to set the complexity and length of both passwords. 6 to 19 keyboard characters. Select the attributes that must be part of the password. Be careful not to lock yourself out as the Module will have to ship to DSX to be reset.

Communication Settings	Device Address Table	Security Settings
Passwords		
User name:	<input type="text" value="123456"/>	
Password:	<input type="password" value="....."/>	Leave blank for no password
Repeat password:	<input type="password" value="....."/>	
Admin User name:	<input type="text" value="master"/>	
Admin Password:	<input type="password" value="....."/>	Leave blank for no password
Repeat Admin password:	<input type="password" value="....."/>	
Password Format	Upper	Lower
	<input type="checkbox"/>	<input type="checkbox"/>
	Special	Numeric
	<input type="checkbox"/>	<input type="checkbox"/>
		Length
		<input type="text" value="0"/>

8a. The User Password allows the changing of the Network Settings only.

Default is > User - 123456 Default Password - 123456

8b. The Admin Password allows the changing of the Security Settings and Network Settings.

Default is > Admin User - master Default Password - master

9. Encryption Key - Future Use - DO NOT SET

Log Settings	
UDP Log Address:	<input type="text" value="IPv4,IPv6 or DNS lookup"/>
UDP Log Port:	<input type="text" value="0"/> Enter '0' to disable logging
Heartbeat Frequency (in seconds):	<input type="text" value="0"/>

10a. The **Log Settings** allow for an optional IP Address and Port to be defined. Once defined The Module will send all Login attempts and notification of changes made to that Log address. Each time you switch between pages it will send a Login. Enter the IP Address and IP Port number to send the information. This is not the Comm Server Address.

10b. Heartbeat-Enter the number of seconds that the Module will send a supervisory message to the Security Log IP Address. This continual heartbeat supervises the communication path.

11a. Enter the UTC Time Zone so these logs have the proper time and date stamp.
-6 for Central Time,
-5 for Eastern Time,
-7 for Mountain Time,
-8 for Pacific Time

Time Settings	
Daylight Savings Time	<input type="checkbox"/> Daylight savings Valid only for TimeZones in US & Canada
NTP server Enable	<input type="checkbox"/> Changing NTP Settings may cause a reboot
Security Log UTC Timezone offset:	<input type="text" value="0"/>
NTP server Address	<input type="text" value="IPv4,IPv6 or DNS lookup"/> Leave blank for time.google.com
System Time:	<input type="text" value="16:11:54"/>
System Date:	<input type="text" value="01/05/2018"/>

11b. Enter the IP Address of the Time Server where the Module can get the proper time.

11c. Click on **Display System Time** to get the time from the module. Enter the time if a Time Server is not available. Once you have entered the date and time click on **Manually Set System Time**. Once the time has been set manually do not power the Module down and up.

Example: Security Log Supervision Message. DEVICE:DSX-00-08-66-10-00-08 New Routing Table flashed 2018-10-26 19:13:13

Performance Settings

Serial Compatibility Mode – Do Not Select

Serial Debug Mode – Do Not Select

DSX-IP-HUB Wiring to a 1040 Master Controller

The DSX-IP-HUB will use the RS-232 port to connect to a 1040 system. It is wired to the Sub output of the Master Controller in parallel with the DSX-1040-CDM. This drawing depicts a standard DSX-LAN Module connected to the Master Controller and the DSX-IP-HUB connected to the CDM for Sub Communication using UDP over the network. The upper box is the wiring inside the Master Enclosure and the bottom drawing is of a standard DSX-LAN module connected to a Sub Enclosure.

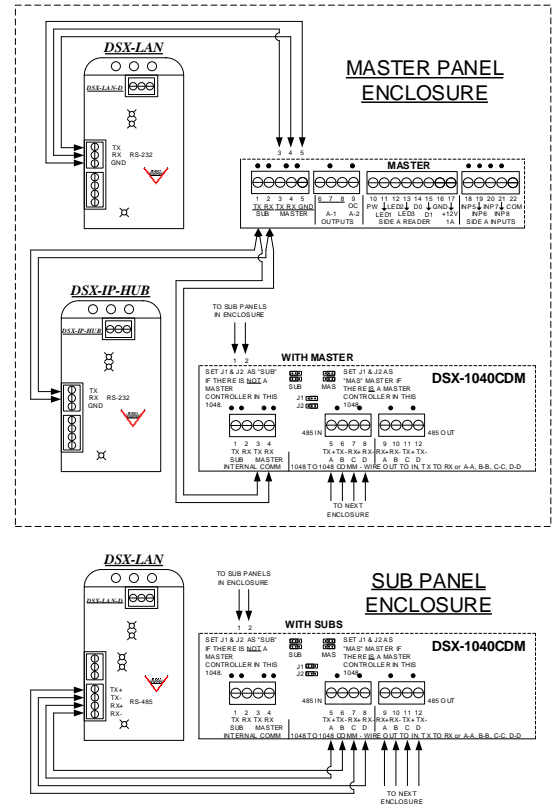

DSX-IP-HUB Wiring to a 1022 Master Controller

This drawing shows a Master 1022 Controller that has no Sub Controllers wired directly to it. The DSX-IP-HUB can be connected directly to the 485 IN port as in the drawing.

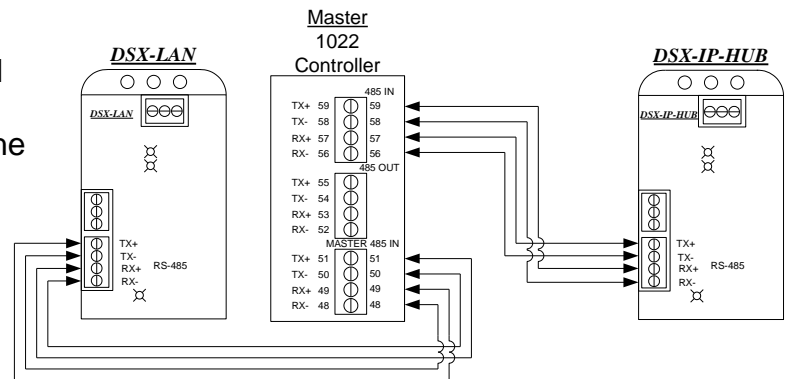

This drawing shows how to connect the DSX-IP-HUB to a 1022 Master Controller when it needs to have Sub Controllers wired directly to it. This will require a DSX-485T wired to the Master Controller. The DSX-IP-HUB and the Sub Controllers are then wired to the DSX-485T.

